

91 honda civic hatchback service manual



File Name: 91 honda civic hatchback service manual.pdf
Size: 4795 KB
Type: PDF, ePub, eBook
Category: Book
Uploaded: 29 May 2019, 16:11 PM
Rating: 4.6/5 from 648 votes.

Status: AVAILABLE

Last checked: 5 Minutes ago!

In order to read or download 91 honda civic hatchback service manual ebook, you need to create a FREE account.

[**Download Now!**](#)

eBook includes PDF, ePub and Kindle version

[Register a free 1 month Trial Account.](#)

[Download as many books as you like \(Personal use\)](#)

[Cancel the membership at any time if not satisfied.](#)

[Join Over 80000 Happy Readers](#)

Book Descriptions:

We have made it easy for you to find a PDF Ebooks without any digging. And by having access to our ebooks online or by storing it on your computer, you have convenient answers with 91 honda civic hatchback service manual . To get started finding 91 honda civic hatchback service manual , you are right to find our website which has a comprehensive collection of manuals listed.

Our library is the biggest of these that have literally hundreds of thousands of different products represented.



Book Descriptions:

91 honda civic hatchback service manual

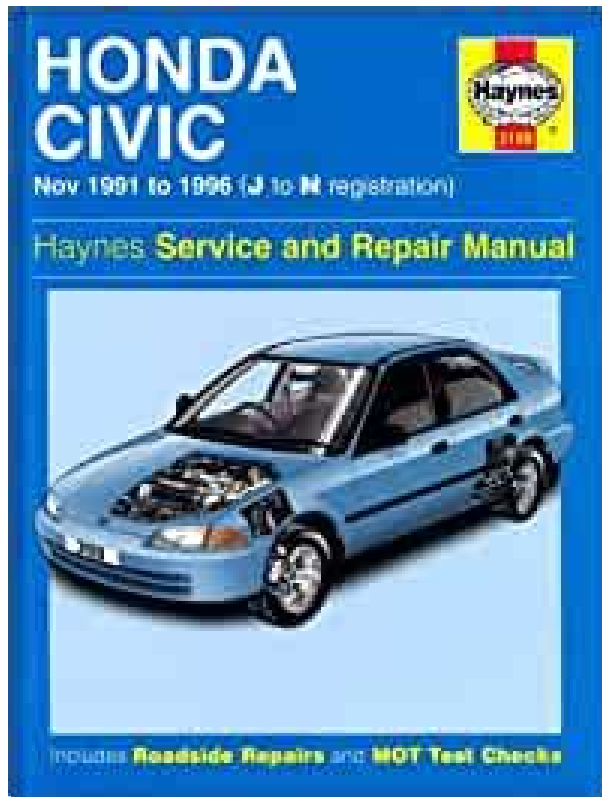

Try our virtual chat tool. Try our virtual chat tool. The Owners Guide provides a quick howto on basic functions and features. If your vehicle is equipped with a navigation system, a navigation manual with detailed instructions, settings, and other information is also available. To save paper and time, you can download the latest manuals now. Details can be found in the Warranty section. To find out more, read our cookie policy. Hello to all, this is a manual i downloaded from www.AVTOS.INFO, a Russian page. Its diferent from the 8891 CRX Manual and VTEC Along with all the other stuff involved in a service manual. Most of it is backwards compatible with the 4th gen civics, but not everything. It really File Download 1991 honda civic si repair manual. 1990 honda civic hatchback repair manual 1989 honda civic repair manual 1991 honda civic service manual Workshop and owners manuals for the Honda Civic. Reload to refresh your session. Reload to refresh your session. Covers all aspects of vehicle repair, including maintenance information, electrical system, engine rebuild and rebuild of other mechanical components, suspension, brakes and interior components along with wiring diagrams. You no longer need an account to download free PDF workshop manuals. We do however have download restrictions so please only download the PDFs you require. The wagon variant was now only available in the Japanese market where the previous generation wagon was carried over until 1995. In New Zealand the powerful Civic was revised. Continuing in the sporty tradition of the original Civic SiR, Honda sold several similarly equipped variants of the fifth generation car, still referred to as the Civic SiR, in Japan, Asia, and Europe. In South Africa, MBSAMercedes Benz of SA built the Civic as the Ballade only in 4dr. A special model was the 180i with the B18B4, that was fitted to Ballade models. <http://megatex-plast.ru/pub/emtec-remote-control-manual.xml>

- **1991 honda civic hatchback service manual, 91 honda civic hatchback service manual, 91 honda civic hatchback service manual car, 91 honda civic hatchback**

service manual pdf, 91 honda civic hatchback service manual 2017, 91 honda civic hatchback service manual 2016.



A new bodystyle was introduced with this generation called the Civic Coupe, based from the Civic Ferio sedan, and was sold in North America, Europe and Japan. With stepbystep instructions, clear pictures, exploded view illustrations, schematics, and specifications, you will have the information you need to get your project on the road and keep it there. Buy now to own the best manual for your car. Why buy a factory manual. Fix it right the first time with the factory repair manual and save money by doing the job yourself. Factory experts prepare these manuals for their dealership service departments, so theyre the most complete and specific source of repair techniques. Repair manuals are also called shop manuals, maintenance manuals, service manuals, or technical information manuals. For a better experience, please enable JavaScript in your browser before proceeding. It may not display this or other websites correctly. You should upgrade or use an alternative browser. Anybody who could direct me to the link please Thanks! Can I see more of your EF hatch please. Really like the front bumper from afar that is! Can I see more of your EF hatch please. Really like the front bumper from afar that is! Im gonna get rid of it as soon as I get enough money for the EF9 front end SiR. I think I some pix in my garage. Im gonna get rid of it as soon as I get enough money for the EF9 front end SiR. I think I some pix in my garage. But what kinda front end is it Thanks! Actually I just wanted to ask if I could download it online similar to what I got with the CRXs. Thanks! You seem to be up at this hour I have that already. Anything you have for the EF hatch please Thanks! Amazon and the Amazon logo are trademarks of Amazon.com, Inc, or its affiliates. We've checked the years that the manuals coverYou'll then be shown the first 10 pages of this specific. Then you can clickSpam free Maximum of 1 email per monthSpam free Maximum of 1 email per month.<http://kythuatviet.vn/uploads/userfiles/emtech-zm-2-manual.xml>



To add a new vehicle, select the year, make, and model at left. Our payment security system encrypts your information during transmission. We don't share your credit card details with thirdparty sellers, and we don't sell your information to others. Please try again.Please try again.In order to navigate out of this carousel please use your heading shortcut key to navigate to the next or previous heading. In order to navigate out of this carousel please use your heading shortcut key to navigate to the next or previous heading. Please try your search again later.Click here to make a request to customer service.They are designed from factory tolerances to fit your vehicle like a factory piece. CIPA's Original Style Replacements Mirrors will bolt right on, with no need to modify the existing bolthole pattern. They have the same appearance, and meet the same quality standards needed to restore your vehicle back to its original look at a fraction of the cost. They are rust and corrosion resistant, and feature OE grade glass. In order to meet the OE standard for glass, these mirrors use first surface plating, which means the reflective chrome layer is plated on the front of the glass. The advantage is less distortion from having to look through the thickness of the glass, but a greater risk from surface scratches. This mirror directly replaces original equipment number 76200SH3A01. Mirror specifications Passenger side right hand, manual remote, gloss black, foldaway, nonheated, with convex glass.To calculate the overall star rating and percentage breakdown by star, we don't use a simple average. Instead, our system considers things like how recent a review is and if the reviewer bought the item on Amazon. It also analyzes reviews to verify trustworthiness. Please try again later. koa 3.0 out of 5 stars The plastic pieces are brittle. The lines dont line up with the car. The material is cheap. The mirror is terrible.

The reflection seems like its a funny mirror from a carnival. Im very dissatisfied. Definitely not OEM. I rather drive with a missing mirror.I knew it wasnt going to be OEM quality, but I expected something a little better. I suggest getting OEM if you can afford to. I had to drill out extra material around the knob to make it function correctly. If you absolutely have to have a mirror to pass an inspection and want to save every penny you can, then this one will work. I just dont suggest it to any who hope to retain factory fitment.I would buy again for replacement Adjusting arm is too short. But overall good value. I would buy again for replacement. It's based on the same platform as the Civic. The hatchbacks are built in the United Kingdom, Si versions are produced in Canada and the regular sedan is made in Greensburg, Indiana, as well as the Canadian factory. Engines and transmissions are assembled in Ohio. Any repairs are usually infrequent and not particularly serious or costly. Most of the other variants aren't far behind. Even the base model, though, has a touch of the "wow" factor in its dynamics. Users had to fiddle with the steering wheel controls. So welcome back, little friend. They have the 2020 Honda Civic as just one of several fantastic choices. There are some factors, though, that nudge the Civic a tad above cars like the Mazda3, Kia Forte, Volkswagen Jetta sedan, Volkswagen Golf hatchback and the newfor2020 Toyota Corolla. Rocksolid reliability is another. The Insurance Institute for Highway Safety IIHS also makes it a Top Safety Pick. It all adds up to an impressive package that has won KBB.com's Small Car Best Buy award for five consecutive years. Models span from a sensible LX to a blazing 306horsepower Type R, with a mildly sporty Si in between. Base models powered by the naturally aspirated 2.0liter engine are quite energetic, especially when the 6speed manual transmission is in the mix.

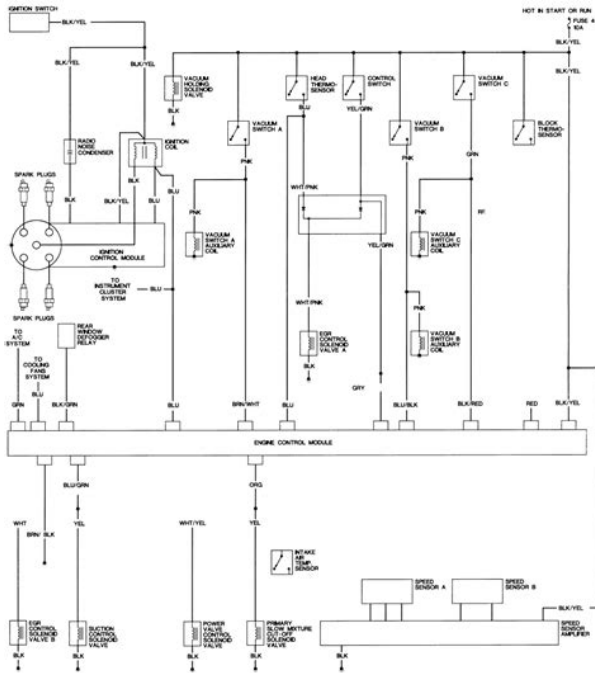

<http://fsc1.ru/content/bose-tone-match-engine-manual>

Unfortunately, a turbocharged engine often means a continuously variable automatic transmission CVT. While Honda's unit is good for a CVT, it's still not as sporty as driving a stick. The first is the 205horsepower Si, topmost is the Type R. Both come with a 6speed manual transmission. Our main gripe with the Si is that it feels short on torque for a sporty machine. The Type R, however, is tremendous even though its focus is necessarily narrow. But the 2020 Civic range in general has an advantage over the rest of its rivals. Apple CarPlay and Android Auto give the driver access to navigation, music, apps and text messages through the infotainment system without having to fumble with their phone. That means ergonomics is spoton, providing comfort and ease of use for drivers of most shapes and sizes. And the infotainment display is large and easy to read at a glance. The cabin also houses plenty of softtouch plastics and other quality materials. Rear legroom in the sedan is an impressive 37.4 inches. Trunk space of 15.1 cubic feet in the regular sedan is commodious, on a par with several midsize sedans. The Civic hatchback also does well with 25.7 cubic feet behind the rear seats and 46.2 cubic feet when they're folded down. This description could apply to the Civic as a whole. The overall styling borders on manic, it's that busy. At least it's memorable. Sport and Sport Touring hatchbacks have dual exhaust outlets, while the Si has its own cosmetic treatment. The Type R receives details a schoolboy might have drawn, including a hood scoop, three exhaust pipes and a massive rear spoiler. For example, the EX comes with the turbocharged 1.5liter engine and CVT, plus LaneWatch a kind of blindspotmonitoring system for the passenger side, power moonroof, poweradjustable driver's seat, dualzone automatic climate control, heated front seats, and satellite radio. EXL adds leather upholstery. The sedan version of the Touring also has heated rear outboard seats.

<https://1866ilovejunk.com/images/canon-mp120-mg-manual.pdf>

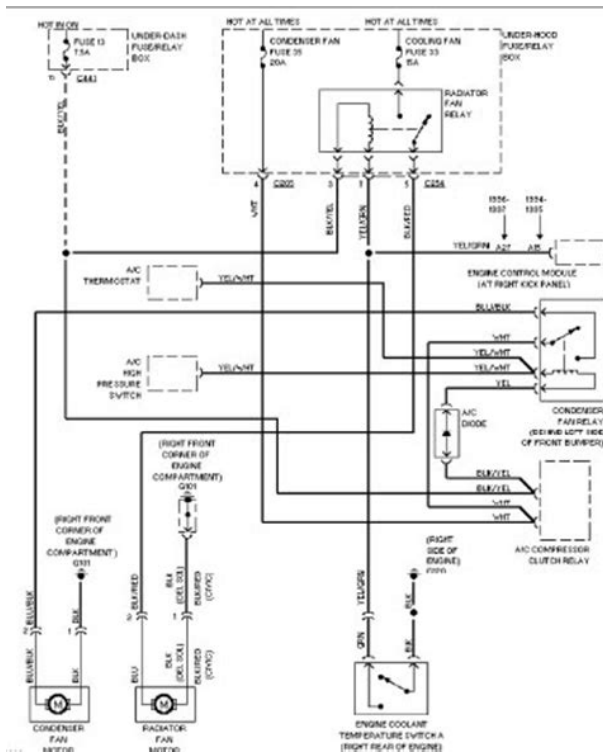

The main option for the Type R is summer tires. A 6speed manual transmission is standard in lower trims, replaced by a continuously variable automatic transmission CVT higher up the pecking order. The Type R deploys one of the most powerful production turbocharged 2.0liter 4cylinder engines to provide a wild 306 horsepower. These sportier machines require premium gasoline, but the lesser models are fine with regular. The Si and Type R have a helical limitedslip differential to apply their power more effectively. Check the KBB.com Fair Purchase Price to see what others in your area are paying for their new Civic. Like every other Honda, the Civic does a great job at retaining its worth. Hondas are good cars. Great gas mileage. the problem is they are overpriced at these dealerships. The biggest problem is stupid Kelly blue book value. Over pay for a vehicle, and then your fcked. All because of Kelly blue book!!!! Value Performance Quality Comfort Reliability Styling 0 0 Was this review helpful. Online apparently Honda knows there is an issue with 20162o18 civics. Trading it in on.a Subaru Crosstrek sport. Value Performance Comfort Reliability Styling 3 0 Was this review helpful. Can you image your new car having an oil leaking problem. Obviously, this car has manufacturer defects. And it is very challenge even for a mechanic car expert to find out what the real problem is. So far, it has been claimed as fixed the 4th times, I lost my confidence on this new car. I contacted American Honda for a replacement vehicle. Per Florida's Motor Vehicle Lemon Law, I am qualifie d for it. The American Honda customer service representative documented my case and assigned me a case number. But the person who is in charge for my case had never responded to me for a month. Finally, she called me back said they had nothing to do with my car problem basically. And the worst thing is she refused to provide me any reason and do NOT want to send me anything in writing. What a service!

<http://florianschlosser.com/images/canon-mp130-printer-manual.pdf>



Read less Value Performance Quality Comfort Reliability Styling 10 1 Was this review helpful. A small camera on the passenger side mirror sends its images to the infotainment touch screen. It's the nearest thing to blindspot monitoring the Civic can offer, but there's nothing for the driver's side. When you're in a car, pickup trucks always seem to have their headlights at eye level. This makes life a little easier; your retinas will thank you for it. Discover everything Scribd has to offer, including books and audiobooks from major publishers. Report this Document Download Now Save Save 1991 Honda Civic Hatchback Sedan Owners Manual For Later 0 ratings 0% found this document useful 0 votes 116 views 136 pages 1991 Honda Civic Hatchback Sedan Owners Manual Uploaded by Lois Riley Durham Description Owner Manual Full description Save Save 1991 Honda Civic Hatchback Sedan Owners Manual For Later 0% 0% found this document useful, Mark this document as useful 0% 0% found this document not useful, Mark this document as not useful Embed Share Print Download Now Jump to Page You are on page 1 of 136 Search inside document Browse Books Site Directory Site Language English Change Language English Change Language. While it is famous for its vehicles, Honda is also the world's largest manufacturer of internal combustion engines, producing more than 14 million units per year. The company originally started out producing motorcycles, but by 1963 had expanded to include car manufacturing. Since then, the company has produced many popular models, including the Accord, Civic, CRV, and Prelude. Honda is actively involved in motorsports and entered Formula One for the first time in 1964. It also took part in the IndyCar World Series for the first time in 1994, and in 2004 won 14 out of 16 IndyCar races. At Haynes, we have an extensive range of Honda repair manuals available for professional mechanics and DIY car enthusiasts alike.

Our manuals will give you all the guidance you need for carrying out full scale servicing, routine maintenance and comprehensive repairs. Learn more on how we're navigating COVID19 in our community. An Important Message from Hendrick Morning Afternoon Evening Please choose a time range above Referral ID Email This field is for validation purposes and should be left unchanged. Referral ID Email This field is for validation purposes and should be left unchanged. All prices and offers include all manufacturer incentives which the dealer retains unless otherwise specifically provided. Dealer not responsible for errors and omissions; all offers subject to change without notice, please confirm listings with dealer. It is a charge that is permitted but not required by law Section 372307. The full cash price charged at any dealership depends on many factors, including all products and services bought with the vehicle. Please contact the dealership for more specific information. All vehicles are subject to prior sale. Through the hole under the car or the opening on top. Or there is a 17mm bolt on the passenger side of the trans next to the axle. You will need a funnel and hose for this way as well. I have done both i work on hondas only. Hettboy that is for a auto trans he has a manual trans. It is black and has 3 wires going to a plug, at the top. I will add a pic. Yes the funnel and hose is used from the top for both methods. I use amsoil manual trans fluid. Even after all this Dropping the gear Considering these models were designed 2 use examples of torque. Oh also seemed 2 find that the most obvious portion of that. is when Changed main

Through the hole under the car or the Jack stands and put it in neutral and let the clutch out the
Please refer to CarGurus Terms of Use. Content will be removed if CarGurus becomes aware that it
violates our policies. We may earn money from the links on this page.

<https://www.bridalchapel.com/wp-content/plugins/formcraft/file-upload/server/content/files/1627efc4c709c4---brother-sewing-machine-service-manual-download.pdf>

Available as either a sedan or a practical hatchback, the Civic is powered by your choice of a 158hp 2.0liter fourcylinder or a turbocharged 1.5liter that makes 174 or 180 horsepower, depending on the model. Honda loads up its smallest car with plenty of standard driverassistance features, including automated emergency braking, adaptive cruise control, and lanekeeping assist. Oddly, modern infotainment features arent standard; the base LX model comes with a tiny touchscreen that offers radio tuning and not much else. The base model notwithstanding, the Civic is a compact car that should satisfy most buyers and one were happy to recommend. If youre seeking something with a spicier flavor, wed suggest the 205hp Civic Si or the 306hp Civic Type R both reviewed separately. Whats New for 2021. Theres no easy way to say this The Civics coupe body style is dead after the 2020 model year. The sedan and hatchback models live on, but Honda is planning an allnew Civic for the 2022 model year. We expect to see that debut in spring 2021. Going with the Sport over the base LX also unlocks a load of equipment, including Apple CarPlay and Android Auto integration, a 7.0inch infotainment touchscreen, an eightspeaker stereo system, a leatherwrapped steering wheel and shift knob, pushbutton start, fog lamps, and a rearseat folddown armrest. Engine, Transmission, and Performance The Civics fourcylinder engines are peppy, with the pricier—but more powerful—turbocharged version earning our preference. Its a terrific engine. In our testing, it eagerly pulled our Civic Touring test car away from stoplights. While we prefer the light and crisp action of the sixspeed manual to the optional continuously variable automatic transmission, the CVT is by no means a poor partner—in fact, its one of the best on the market. A true jackofalltrades, the Civic strikes a great balance between comfort and driver engagement.

Its smooth ride, responsive steering, and athletic driving dynamics make it a joy to pilot. Neither cushy nor harsh, the Civics ride quality is just right. Quick, well weighted, and surprisingly feelsome steering makes the Civic that much more enjoyable to pilot. Those looking for even sportier vibes should consider the Sport versions, which feature quicker steering. Despite possessing a firm brake pedal with good feel, the brakes lack the stopping prowess of competitors. Both Civic fourcylinders sip fuel as frugally as if it were fiftybucksasnifter brandy, but, interestingly, the more powerful turbocharged engine manages to return slightly better fuel economy than the base 2.0liter found in lowerlevel Civic sedans. Unfortunately, the Civics fuel economy failed to pan out in our realworld highway fueleconomy test. Our turbo Civic Touring sedan scored just shy of the EPAs rating. Furthermore, we eked out 37 mpg from a sixspeed manual Civic Sport hatchback—2 mpg less than the EPA number. Interior, Comfort, and Cargo Practical and modern in appearance, the Civics interior is roomy and offers sufficient storage space. Even the entrylevel model is far from a penalty box. While it doesnt offer the most optional comfortandconvenience equipment in the compact class, it has enough of the good stuff for any smallcar shopper. The interior of both the sedan and hatchback is on the roomier end of its class. The Civic has a number of cleverly designed storage cubbies throughout its cabin, and the sedans trunk is one of the biggest in the class. Need even more cargocarrying capability. Then check out the hatchback model. The toptier Touring sedan we tested served up infotainment features through its 7.0inch touchscreen, including navigation, SiriusXM satellite radio, and Apple CarPlay and Android Auto connectivity. The front compartment has two USB ports and a single 12volt outlet.

Sadly, rearseat passengers are left unconnected, as not a single USB port or 12volt outlet makes its way past the Civics front seats. Safety and DriverAssistance Features Paired with solid crashtest scores, the Civic is a fine option for those who prioritize safety. Every Civic also has a host of

driver assistance features including automatic highbeams and forward collision warning. Honda gathers these features together under the Honda Sensing umbrella. Key safety features include Standard automated emergency braking Standard adaptive cruise control Standard lanekeeping assist Warranty and Maintenance Coverage Those seeking the best warranty coverage may be better off looking at a competitor such as the Hyundai Elantra. Honda does not offer complimentary scheduled maintenance, a feature that's included on competitors such as the Toyota Corolla. Limited warranty covers 3 years or 36,000 miles Powertrain warranty covers 5 years or 60,000 miles No complimentary scheduled maintenance. Please try again later. Please try again. Please try your search again later. You can edit your question or post anyway. Established in 1926, CIPA France has played a major role in the design evolution of rearview mirrors. Clients in the European market include BMW, Mercedes, Renault, Volvo and Volkswagen. In the US market, CIPA mirrors can be found on Chrysler and Ford vehicles, plus some of the finest motorcycles, boats, ORVs, personal watercraft and snowmobiles manufactured. Since 1985, CIPA USA has been a privately held U.S. Corporation operating in Port Huron, Michigan. CIPA has continued to show healthy growth year after year. CIPA currently manufactures its products in the U.S, Asia and France, and continues to provide high quality, fast moving products setting sales volume records in almost every category sold. CIPA's high level of customer service and just in time deliveries have converted CIPA from just a mirror supplier to a business partner.

In 1987, CIPA entered the marine industry as a supplier of rearview mirrors to tournament ski boat manufacturers. Today, CIPA supplies mirrors to 100% of the tournament ski boats manufactured in the U.S. Since its entry into the marine industry, CIPA has introduced many innovative mirrors to enhance rearview safety in the family recreational and PWC segments. To calculate the overall star rating and percentage breakdown by star, we don't use a simple average. Instead, our system considers things like how recent a review is and if the reviewer bought the item on Amazon. It also analyses reviews to verify trustworthiness. Sorry, we failed to record your vote. Please try again The plastic pieces are brittle. The lines don't line up with the car. The material is cheap. The mirror is terrible. The reflection seems like it's a funny mirror from a carnival. I'm very dissatisfied. Definitely not OEM. I rather drive with a missing mirror. Sorry, we failed to record your vote. Please try again I knew it wasn't going to be OEM quality, but I expected something a little better. I suggest getting OEM if you can afford to. I had to drill out extra material around the knob to make it function correctly. If you absolutely have to have a mirror to pass an inspection and want to save every penny you can, then this one will work. I just don't suggest it to any who hope to retain factory fitment. Sorry, we failed to record your vote. Please try again Sorry, we failed to record your vote. Please try again Sorry, we failed to record your vote. Please try again I would buy again for replacement Adjusting arm is too short. But overall good value. I would buy again for replacement. Sorry, we failed to record your vote. Please try again Sorry, we failed to record your vote. Please try again. Request a quote now. Get Started Request a quote now. Get Started No problem! There are HUNDREDS of vehicles on their way to Valley Honda. Request a quote now.

Yes No Other Comments Use for comparison purposes only. MSRP does not include Tax, Title, License, and Doc fee. While great effort is made to ensure the accuracy of the information on this site, errors do occur so please verify information with a customer service rep. This is easily done by calling us at 630 8515700 or by visiting us at the dealership. MSRP does not include Tax, Title, License, and Doc fee. While great effort is made to ensure the accuracy of the information on this site, errors do occur so please verify information with a customer service rep. This is easily done by calling us at 630 8515700 or by visiting us at the dealership. This unique Civic model offers drivers everything they've come to expect from a Civic like a dependable performance thanks to its 174hp 1.5L Turbocharged and Intercooled, DOHC 4cylinder engine and CVT transmission and paddle shifters for greater control. Take a look to see which new Honda Civic Hatchback for sale meets your needs. These are just some of the available comfort and driver assist features you can expect Take

some time to compare the Honda Civic Hatchback vs. Sedan as well. The VX trim level lived up to the Civics subcompact roots as Hondas most efficient vehicle. The performanceoriented Si trim continues to be a favorite among the aftermarket tuning scene to this day. Phone This field is for validation purposes and should be left unchanged. Referral ID Are you a robot. Phone This field is for validation purposes and should be left unchanged.

<https://formations.fondationmironroyer.com/en/node/11325>